

Filters FEL

SPIRO DUCT + FITTINGS + GRILLES + DIFFUSERS + FILTERS + FLEXIBLE DUCT + ACCESORIES

Electrostatic filter with synthetic filtering media that is electrostatically charged when the air passes through, which makes the dust to be retained more efficiently.

The electrostatic Filter is a Merv 7 filter and can retain most of the pollutants in the enviroment, such as dust, pollen and dust, pollen and fibers.

1 Principial Features

Materials:

Manufactured with galvanized sheet metal frame, anti-microbial electrostatic media, polyester media and galvanized sheet metal mesh exterior supports.

Applications:

Recommended for residential, commercial and industrial use.

Cleanliness:

To wash the filter it is necessary to apply warm water at medium pressure at counter-flow (in the opposite direction to the air flow), it is not necessary or advisable to use chemical products such as cleaners or degreasers, in any case only soap (common detergent) can be used.

Sizes:

Available in sizes from 6" x 6" to 48" X 48"

The real measure of washable metal filters is ¼ inch smaller than the nominal size, both in width and height and in thicknesses of:

Listed	Unit	Thickness Measure
1	inch	7/8 real
2	inch	1 3/4 real
1 1/2	inch	1 1/2 real
4	inch	3 3/4 real
1/2	inch	1/2 real

2 Views

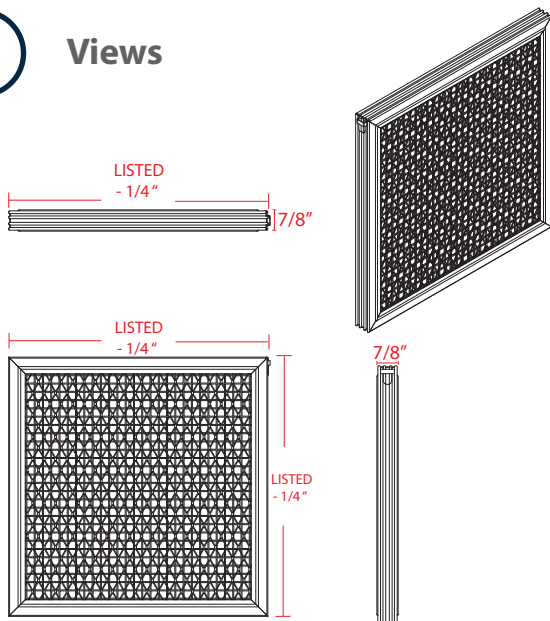

PACKAGING:
Individual hermetic plastic packaging.

Filters FEL

SPIRO DUCT + FITTINGS + GRILLES + DIFFUSERS + **FILTERS** + FLEXIBLE DUCT + ACCESORIES

3 Performance Table

Flow Rate (cfm)	DP "H ₂ O	Size Range (µm)	Initial Fractional Efficiency(%)
205	0.037	0.3-0.4	0.1
410	0.093	0.4-0.55	0.7
615	0.170	0.55-0.7	2.3
819	0.259	0.7-1.0	7.7
1024	0.360	1.0-1.3	18.6
		1.3-1.6	31.7
		1.6-2.2	42.6
		2.2-3.0	51.8
		3.0-4.0	56.6
		4.0-5.5	59.0
		5.5-7.0	60.6
		7.0-10.0	63.2

