

ROUND FITTINGS

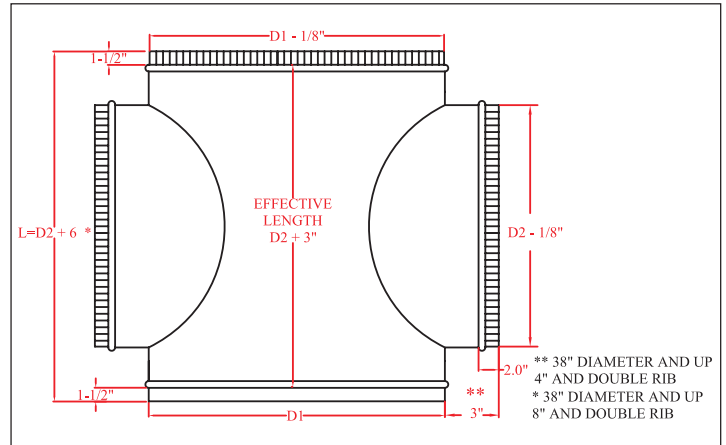

90° Cross

Code: CRU90
 90° cross, galvanized sheet. Gauges 26,24,22 y 20 according to the dimensions.



$D1$ = Duct Diameter, $D2$ = Ramal Diameter. Units are in inches, available in sizes from 4" to 60" in intervals of 2".

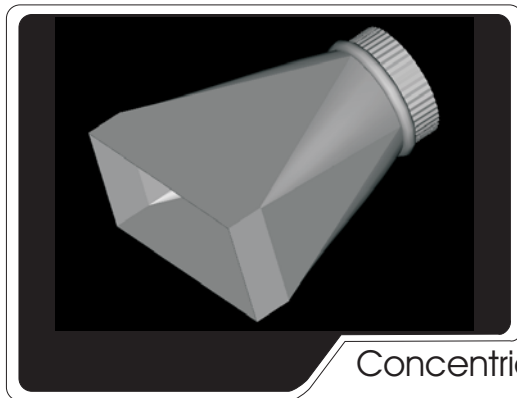

Concentric Reducer

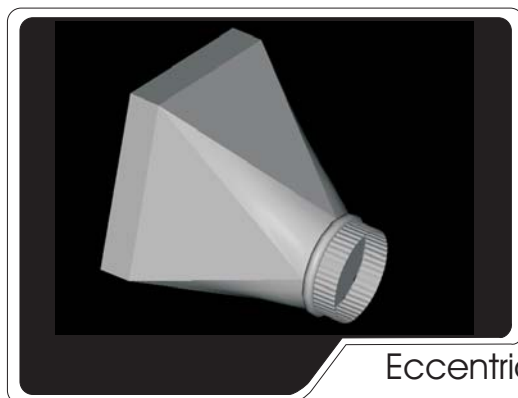
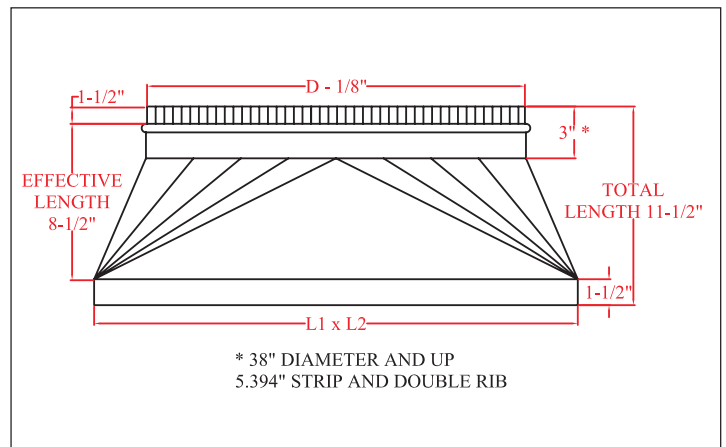

Eccentric Reducer

Code: TRC & TRE
 Transformation from square to round. Concentric and eccentric of galvanized sheet gauges 26, 24,22 y 20.

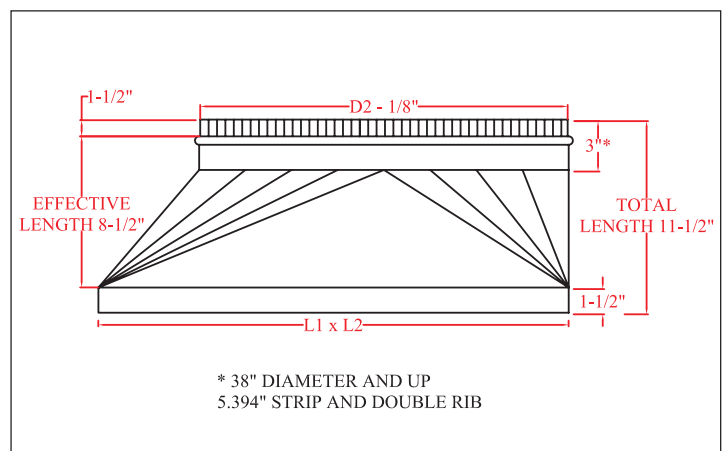

$L1$ and $L2$ = Square duct dimensions. $D2$ = round duct diameter. Units are in inches, available in sizes from 6" to 60" in intervals of 2".

AIR DISTRIBUTION PRODUCTS

SPIRO DUCT + GRILLES + FITTINGS + DIFFUSERS + FILTERS + FLEXIBLE DUCT + ACCESSORIES

Verbet reserve the right of making any change without any prior notice.