

DPP

DESCRIPTION:

- Perforated ceiling diffuser with (24" x 24") :
- + Perforated steel with 50% free area distribution.
 - + High efficiency distribution plate of polyurethane (1/2" thickness) completely enclosed with aluminum foil as a vapor barrier.
 - + Round neck to easily connect with flexible duct.

MATERIALS:

Perforated sheet steel in 26 gauge (24 optional) with injected polyurethane adapter-box of 1/2" of thickness and aluminum foil.

FINISH:

Electrostatic baked paint (polyester) in Vermont white, perforated face plate and airtight packaging.

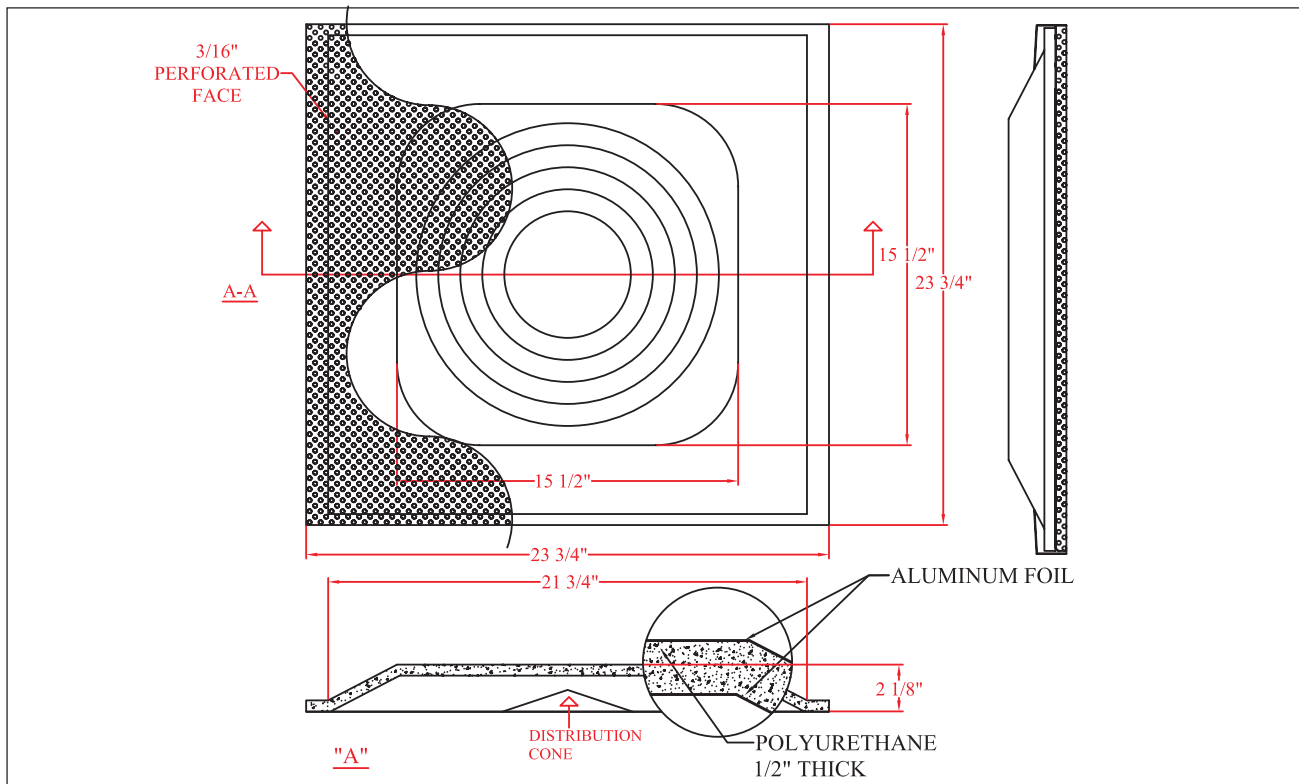

AIR DISTRIBUTION PRODUCTS

SPIRO DUCT + FITTINGS + GRILLES + DIFFUSERS + FILTERS + FLEXIBLE DUCT + ACCESSORIES

Verbet reserve the right of making any change without any prior notice.